

# SGM series

## AC Resonant Test System



**SGM3200KVA/800KV**  
**Helsinki University (Finland)**

### Applications & Advantages

**Resonant Test Systems, type SGM is applied** for the generation of a continuously variable alternating (AC) voltage of a fixed frequency (mainly 50 or 60 Hz) for high-voltage (HV) routine, type and development testing of capacitive test objects. They can also be applied for HV on-site tests, but SAMGOR offers for that application the more economic solution of frequency-tuned resonant test systems.

Capacitive test objects are cables, capacitors, gas

insulated switchgear (GIS), but also large rotating machines, instrument and power transformers (for applied voltage tests). Resonant test systems enable not only HVAC tests at 50/60 Hz, but also at higher or lower frequency (20-300 HZ) and dynamic tests with fast voltage changes (e. g. for capacitors). Because of their precise sine-wave, resonant test systems are very well suited for the combinations of HVAC withstand tests with partial discharge (PD) measurement. **SAMGOR** adapts the resonant test systems to the requirements of the relevant standards and the demand of the customer.

**The main advantage** of resonant test systems is the low power demand, because only the losses in the test circuit must be replaced from the power supply. The quality factor  $Q$  which is the relation between the test power  $S$  and the loss power  $P$  ranges between  $Q = 10$  and values up to 100, this means only 10 to 1 % of the test power must be supplied. A resonant test system is remarkably lighter, cheaper and more economic than an AC transformer test system and should be applied if the test objects are capacitive. In case of a disruptive discharge the test object is not destroyed, because the system goes out of resonance. SAMGOR resonant test systems are characterized by a very modern system configuration and have proven highest reliability.

Tunable reactor modules for series resonant circuits are available between 50 and 1600 kV and test power between 50 and 37500 KVa.

Tunable frequency modules for series resonant circuits are available between 100 and 1600 kV and test power between 50 and 9000 KVa. (Typical Frequency adjustment: 10-300 HZ)

## Standards:

GB10229	《Reactor》
JB/T9641	《Test Transformer》
GB1094.3	《Electric Transformer》 Third Part Insulation Level and Insulation Test
GB/T 16927.1	《High Voltage Test Technology》 First Part Common Test Requirements》
GB/T 16927.2	《High Voltage Test Technology》 Second Part Measurement System
GB/ 7354	《Partial Discharge Test》
GB/ 7328	《Transformer and Reactor's Sound Level Measurement》
JB 8749	《Voltage Regulator's General Technologies' Requirements》
JB/T8638	《Voltage Regulator Test Guidelines》 First Part
JB/T563	《Coupling Capacitor and Capacitor Divider Placing Order Technology Requirement》
GB2536	《Transformer Oil》



1200KV/3A Module Tunable  
Reactor Resonant Test System



350KV/10A Tank type Tunable  
Reactor Resonant Test System



1000KV/5A Module Tunable Frequency  
Resonant Test System (Oil Type)

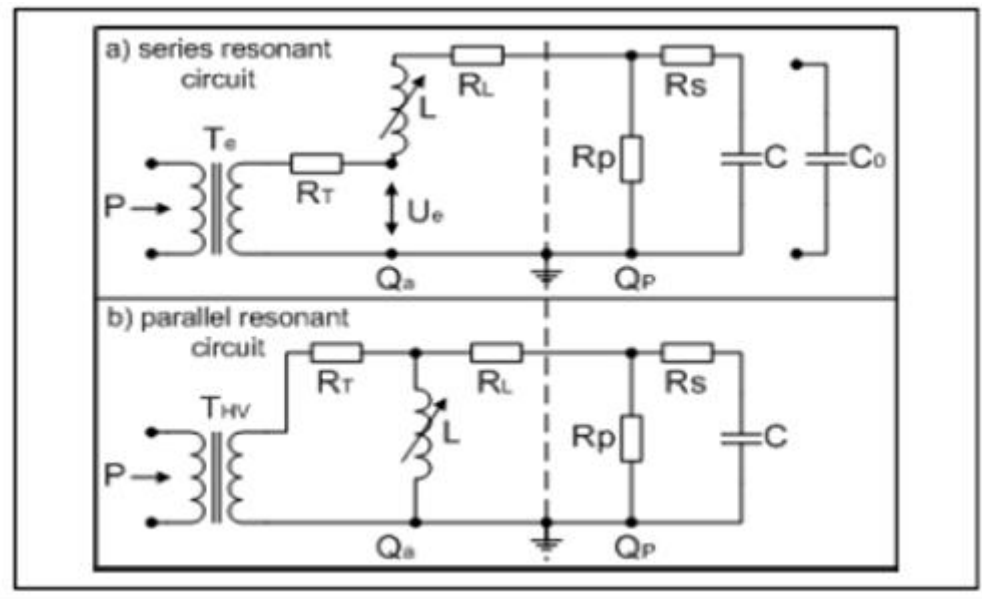

**Fig. 1:** Principle circuit diagrams ( $T_e$ -exciter transformer;  $R_T$  and  $R_L$ -loss resistors;  $L$ -variable inductance;  $T_{HV}$ -HV transformer;  $C$ -test object;  $R_p$  and  $R_s$ -loss resistors;  $C_o$ -basic load)

## Fundamentals

The connection of an HV reactor (inductance  $L$ ) to an capacitive test object ( $C$ ) forms an oscillating circuit with the natural frequency.

$$f = 1/2\pi\sqrt{LC}.$$

By a variable inductance this frequency can be tuned to that of the power supply (e. g. 50 Hz) which means resonance (Fig. 1). The capacitive test power  $S$  exceeds the feeding power  $P$  according to the quality factor  $Q$  of the whole circuit is the combination of that of the test system  $Q_A$  and that of the test object  $Q_P$  by:

$$Q = Q_A \times Q_P / (Q_A + Q_P) \quad (1)$$

For the more important series resonant circuits (**Fig. 1**) resonance is connected with the increase of the voltage from the exciting voltage  $U_e$  to the test voltage  $U$ :

$$U = Q \times U_e. \quad (2)$$

**Parallel resonant circuits** can be understood as HV current compensation by a variable inductance in parallel to a HV test transformer. In that case the voltage is determined by the ratio of the HV transformer. Parallel resonance is only applied if capacitances or losses of the test object are not stable (e. g. at rotating machines) or if the tests include dynamic processes.

The inductance of the HV reactor can be varied only in a certain range (e. g.  $L_{max} = 20 L_{min}$ ), for **series resonance circuits** the load capacitance can be varied in a corresponding limited load range ( $C_{max} = 20 C_{min}$ ). The system must be equipped with a basic load capacitor  $C_o > C_{min}$  which enables no-load operation, but reduces the test object capacitance to ( $C_{max} - C_o$ ). **Fig. 2** shows the load voltage characteristic for a system with two taps at the reactor, each corresponding to a certain inductance and voltage. In the double logarithmic load-voltage characteristic (Fig. 2) both, powers  $S$  and currents  $I$ , are given by straight lines. When the system is e. g. be designed according to the constant current of  $I_1$ , the hatched area cannot be used because of too high current  $I_2$ . A clear definition of the necessary load-voltage requirement including duty cycle is the basis for an economic selection of a resonant circuit.

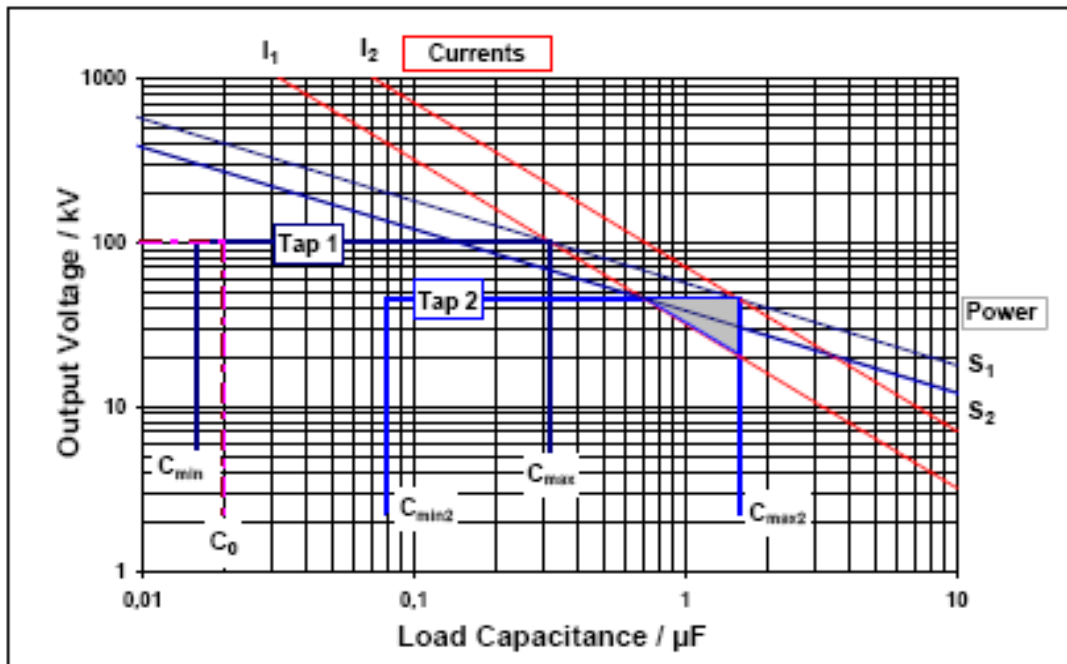

**Fig. 2:** Load-voltage characteristic of a series resonant system with a reactor of two taps

### The Test System includes following main components:

1. Tunable series Resonant Reactor (50Hz/60Hz or 20-300Hz)
2. Voltage Regulator (50/60Hz)
3. Tunable Frequency Power Source (20-300Hz)
3. Capacitive Voltage Divider (Adding Inductance is a High Voltage Filter)
4. Resonant Capacitor (also Coupling Capacitor for PD Measuring System)
5. Manual/Automatic Control and Measuring System
6. Power Noise Filter (50Hz/60Hz)
7. Exciter Transformer

### Available Options

- Air-cushion base frame for transformers (AeroGo)
- HV filter inductance for coupling capacitor
- Standard capacitor
- Additional HV connections
- Partial Discharge detectors
- Capacitance and power loss factor measuring bridges
- Other devices upon request.

## Ambient Conditions for the AC Test Equipment

---

- Height above sea level	≤1000 m
For each add. 100 m, the HV rating must be decreased by	1 %
- Relative humidity in main hall under non condensing conditions	90 %
- Temperature averaged over 24 h for H.V. components	min. 0 °C, max. + 30 °C
- Extreme temperatures for H.V. components	min. - 5 °C, max. + 40 °C
- Temperature for electronic controls (Equipment to operate with the specified measuring errors)	min. + 15 °C, max. + 25 °C

---

For further information please contact:

---

---

**SHANGHAI JIU ZHI ELECTRIC CO., LTD.  
(Samgor Technology)**

Add: 9F, Founder Tower No.1122 Xin Jin Qiao Rd.  
Pudong, Shanghai, 201206, China

Tel: 86-21-58999552 58999556

Fax: 86-21-68482953 50323350

E-mail: [info@samgor.com](mailto:info@samgor.com)

Http:// [www.samgor.com](http://www.samgor.com)

