

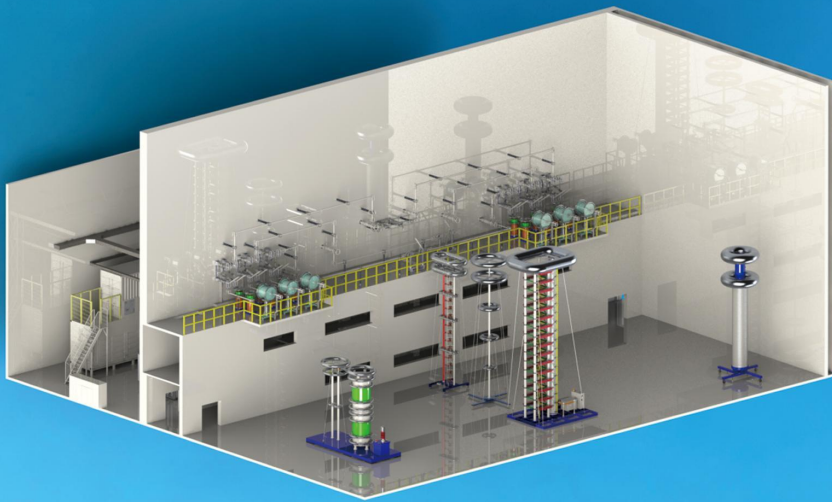

PTTS Series

POWER TRANSFORMER/REACTOR TEST SYSTEM



- ✓ Transformer No-load/Load Test IEC60076-1
- ✓ Transformer Induced Voltage Test IEC60076-3/IEC60270
- ✓ Transformer Temperature Rising Test IEC 60076-2
- ✓ Transformer Applied Voltage Test IEC60076-3
- ✓ Reactor Loss Measurement IEC60076-6
- ✓ Reactor Induced Voltage Test/PD Measurement IEC60076-6/IEC60270
- ✓ Reactor Temperature Rising Test IEC60076-3/IEC60076-6
- ✓ Impulse Voltage Test IEC60076-4
- ✓ Zero Sequence Impedance Measurement IEC60076-1
- ✓ Other Routine Test IEC60076



PTTS Series

POWER TRANSFORMER/ REACTOR TEST SYSTEM

Brief

PTTS Series Power Transformer / Reactor Test System is designed for the routine test and type test for those power transformers and reactors. The system is able to match the routine test requirement for AC power transformer and reactor of up to 1000kV or that for the converter transformer of up to ± 1000 kV.

PTTS Series Power Transformer / Reactor Test System has consisted of many competitive equipment in the world with our own intellectual property right such

as SGVF series PD free electronics power source, TLMS series transformer loss measurement system, CDYQ series impulse voltage generator, YL series SF6 standard capacitor, SGCB series HV capacitor bank and etc. All these equipment has good performance to bring the perfect cost performance ratio for the whole PTTS system. Furthermore, our PTTS use the container structure and prefabricated parts so as to save the constructing period by more than 50% and reduce the workplace area by more than 25%.

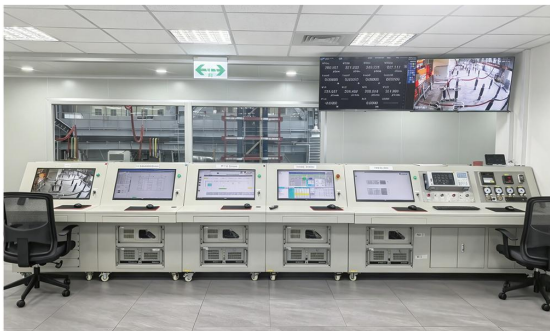

PTTS Series Power Transformer / Reactor Test System has highly automatic control system, which combines various sub-system control, monitoring, safety interlock, data measurement, data storage, test report generating, and data uploading to internet. All of them helps to reduce the labor intensity to the maximum, and to improve the system safety and measurement accuracy. It complies with the safety standard including EN#50191, ISO#13850, ISO#13849, CSA#Z-432, CSA# C22.10-10, IEC 60947-5, ISO 13849-1.

Advantage

- ✓ Overall laboratory construction consulting service;
- ✓ Able to do PD measurement for the power transformer of up to 500kV class, without the shielded room;
- ✓ Module design, container structure, quick delivery;
- ✓ Easy to extend the capacity in the future ;
- ✓ Highly automatic, reducing labor intensity;
- ✓ Fully meet all the factory test requirements for power transformer & reactor ;
- ✓ Easy maintenance;
- ✓ Good safety, meeting the highest safety level;

Core Products

SGVF Series Electronics Power Source

Up to 15000kVA, 0.69-20kV, 16.6-250Hz, <10pC



- ◆ High power capacity & customization
- ◆ Ultra-Low partial discharge (<10pC)
- ◆ Superior harmonic performance
- ◆ Perfect for impact loads (OLTC Testing)
- ◆ Independent phase voltage adjustment
- ◆ Real time input power factor correction & inrush current limited
- ◆ Input power factor >0.95, no pollution to the grid network

TLMS Series Transformer Loss Measurement

Up to 200kV, 6000A

- ◆ High accuracy, with low power factor ($\pm 1.15\%$ when power factor is 0.008)
- ◆ Wide measurement range 10V~200kV, 0.5A~6000A, 40Hz~200Hz
- ◆ Manual/automatic shifting current & voltage taps
- ◆ All the ratios can be shifted at load condition
- ◆ High accuracy at full measurement range of voltage and current taps
- ◆ Low partial discharge



SGCB Series Automatic HV Capacitor Bank

Up to 252kV, 1200MVar



- ◆ Remote control, pneumatic switching, Y/D shift, single/three phase shift, safe grounding switch
- ◆ Cascade structure, quick installation and commissioning within 14 days
- ◆ High safety, protection fuse, self health checking software
- ◆ customized structure, capacity, voltage, frequency
Option for PD free design for reactor testing (<100pC)

Block Diagram

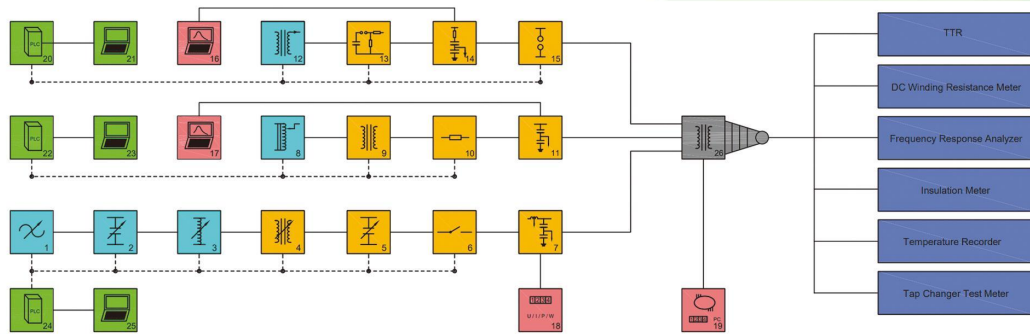

- | | | |
|--|--|--------------------------------|
| 1 Electronic Power Source | 4 Step-up Transformer | 10 Protection Resistor |
| 2 Middle Voltage Compensation Capacitor Bank | 5 High Voltage Compensation Capacitor Bank | 11 AC Voltage Divider |
| 3 Middle Voltage Compensation Reactor Bank | 6 High Voltage Isolation Switch | 13 Impulse Voltage Generator |
| 8 Voltage Regulator | 7 Transformer Loss Measurement System | 14 Weak Damped Voltage Divider |
| 12 DC Charging Device | 9 AC Applied Voltage Test Transformer | 15 Chopping Gap Device |
| 20 Impulse PLC Control Cabinet | 16 Impulse Voltage Measurement System | |
| 21 Impulse Control Desk | 17 AC Voltage Measurement System | |
| 22 AC Applied Voltage PLC Control Cabinet | 18 Power Analyzer | |
| 23 AC Applied Voltage Control Desk | 19 Partial Discharge Detector | |
| 24 PTTS PLC Control Cabinet | 26 Test Object | |
| 25 PTTS Control Desk | | |

Typical Test Lab Configuration:

Transformer Voltage Class	66kV	110kV	220kV	500kV	750kV	1000kV
SGVF-EPS	500kVA	1000kVA	2000kVA	4000kVA	6000kVA	8000kVA
Step-up Transformer	1000kVA	2000kVA	4000kVA	6000kVA	8000kVA	10000kVA
HV Capacitor Bank	15MVar	60MVar	120MVar	180MVar	240MVar	400MVar
TLMS	50kV 1000A	50kV 2000A	100kV 2000A	150kV 3000A	150kV 4000A	200kV 5000A
Impulse Voltage Generator	600kV 60kJ	800kV 80kJ	1600kV 160kJ	2400kV 360kJ	3600kV 540kJ	4800kV 720kJ
AC Test Transformer	200kV 1A	300kV 1A	300kV 1A	300kV 1.5A	600kV 2A	600kV 2A
HV Lab Size	15x10x8m	21x14x9m	20x25x13m	30x25x18m	30x30x20m	35x35x25m
Machine Room Size	15x5x5m	21x10x7m	20x10x13m	30x15x13m	30x20x13m	35x20x15m

MORE INFORMATION:
SAMGOR TECHNOLOGY



TEL: 86-21-58999552

EMAIL: INFO@SAMGOR.COM

WEB: WWW.SAMGOR.COM