

SGADI Series

High Voltage Module AC/DC/Impulse Test System



The high voltage modular AC/DC/Impulse test system is design to be used to test up to 200kV AC voltage, 260kV DC voltage, 240kV LI and 200kV SI. This modular test system is available in a variety of configurations and can be easily expanded at a later date.

Due to its modular design and high flexibility it is not only widely used for factory and on-site testing of components in distribution networks, but it is also used for research, development, training, and education for students.

Main component of **The high voltage modular AC/DC/Impulse test system** it is a 100 kV AC test system. It can effortlessly be extended by additional components for higher AC voltages or even different voltage shapes such as DC or impulse.

A digital control and measuring system is used to be control the difference output AC/DC/Impulse and related protection device such as over voltage and over current, in the meanwhile, it is also measuring rated voltage /current/power/frequency/waveform/partial discharge. It offers a variety of advantages as semi or fully automatic operation, data storage and report generation.

Applications:

- ◆ Research & Development
- ◆ Factory Testing
- ◆ Education
- ◆ Diagnostic Onsite Testing
- ◆ Training

Testing Applications:

- ◆ AC Apply Voltage Test
- ◆ DC Apply Voltage Test
- ◆ LI Impulse Voltage (1.2/50us)
- ◆ SI Impulse Voltage (250/2500us)
- ◆ Partial Discharge Measurement
- ◆ Capacitance & Tan Delta Measurement
- ◆ Corona Simulation

Benefit and Advantage:

- ◆ Modular design allows future expansions;
- ◆ Very Compact design;
- ◆ Efficient space usage by combining AC/DC and impulse voltages in one test system;
- ◆ Standard CE power plug 63A;
- ◆ Lowest partial discharge guarantee, typical <2pC;
- ◆ Fast rearrangement without special skills;
- ◆ Semi or automatic control and measuring system;
- ◆ Fast assemble and disassemble the components by quick coupling connector;

Main Components:

◆ Single Phase AC Test Transformer (TT)

Test transformer which can be used for AC, DC and impulse voltage generation. The output power can be extended by cascading the transformers. (SF₆ filled and Oil filled available)

Rated power:	10kVA
Input voltage:	220V/380V
Input current:	45.5A/26.3A
Output voltage:	100kV
Output current:	10mA
Impedance voltage:	5%
Frequency:	50/60Hz
Partial discharge:	<2pC
Duty cycle:	1 Hour

(The power rating can be specially ordered according customer's requirement.)

◆ Voltage Regulator (VR)

Voltage regulator is used to regulate the input voltage for test transformer; the output voltage from test transformer will follow to change.

Rated power:	10kVA
Rated input voltage:	0.22kV/0.38kV
Rated input current:	45.5A/26.3A
Rated output voltage:	0-0.42kV
Rated output current:	25A
Impedance voltage:	<12%
Cooling method:	AN
Frequency:	50/60Hz
Duty cycle:	1 Hour

(The power rating can be specially ordered according customer's requirement.)

◆ Damped Resistor (DR)

Damped resistor is used to limit the output current of test transformer when flashover happened.

Rated voltage:	100kV
Rated resistance:	10kohm
Temperature rise:	<55k

Frequency:	50/60Hz
Duty cycle:	1 Hour

◆ Coupling Capacitor & Divider (CC)

Coupling capacitor & divider consist of one high voltage capacitor and one secondary capacitor. It can used to measure the partial discharge, the same time it also can used to be a high voltage divider to measuring the AC high voltage. The voltage level can be extended by cascading the capacitor.

Rated voltage:	100kV
Rated capacitance:	500pF
Tan delta:	<0.2%
Divider ratio:	1000:1
Frequency:	50/60Hz
Partial discharge:	<2pC
Duty cycle:	1 Hour

◆ HV Rectifier + Protection Resistor (RE)

Rectifier, which can be used for impulse and DC voltage configurations.

Protection resistor:	50k Ω
Inverse peak voltage:	140kV
Rated current:	200mA
Duty cycle:	1 Hour

◆ Resistive Divider (RD)

Resistive divider is used to measure the HV DC voltage also the charging voltage of the impulse capacitor.

Rated resistance:	280M Ω/560 M Ω
Rated voltage:	140kV/280kV
Rated current:	0.5mA
Divider ratio:	1000:1
Duty cycle:	1 Hour

◆ Smooth Capacitor & Impulse Capacitor (SC & IC)

Capacitor is used as energy storage capacitor for generate impulse voltage or smoothing capacitor for DC generation.

Rated capacitance: 100nF
 Rated DC & IMP voltage: 140kV/280kV
 Duty cycle: 1 Hour
 (The capacitance rating can be specially ordered according customer's requirement.)

◆ **Grounding Switch (GS)**

Remote controlled switch, which can be used to ground the high voltage construction KIT.

Rated DC & IMP voltage: 140kV/280kV
 Service voltage: 24V, 50/60Hz

◆ **Air Operation Sphere Gap (SG)**

Sphere gap is triggered what operate by air pressure.

Max. IMP voltage: 140kV/280kV
 Sphere diameter: 150mm/250mm
 Max. gap distance: 100mm/300mm

◆ **Front/Tail Wave Resistor (RD)**

Front/Tail wave resistor, which can be used as series resistor for impulse voltage configurations, determining the front and tail wave time.

Resistance value: 10-500 Ω
 Max. IMP voltage: 140kV/280kV

◆ **Weak Damped Capacitive Voltage Divider (DL)**

Weak damped capacitive voltage divider is used to be measure the impulse voltage, also use as a basic load of the impulse generator.

Max. IMP voltage: 140kV/280kV
 Rated capacitance: 400pF
 Response time: <95ns
 Divider ratio: 500:1

◆ **Digital AC/DC/Impulse Control System (ACS-1)**

Digital AC/DC/Impulse control system is used to be control the switchgears, voltage regulator, impulse trigger, in the mean time, it is also used to measure the rated

voltage and current in the system. Necessary protection function is included. The software is base on the Window 10 platform and Labview software.

Industry Platform: TFT 23.5' TFT Screen
 Operating system: Window 10 or Window 8
 I/O control: Mitsubishi PLC
 A/D sampling: Mitsubishi PLC
 D/A output: Mitsubishi PLC
 Channel of measuring: 8
 A/D accuracy: 0.5% (16bit)

◆ **Digital AC/DC Measuring System (SG3005)**

The Digital Measuring Instrument SG3005 is a microprocessor controlled device for accuracy measuring AC, DC and also can be used for testing voltage waveform distortion and ripple factor.

The SG3005 has implemented a flash detector which stores and shows the last voltage measurement and its polarity before a breakdown or flashover occurs.

AC Measurement

Measurement modes: peak, peak/2, rms
 Input Voltage range: 0 ... 700 V rms
 Frequency range: 16 ... 1000 Hz
 Accuracy: 0.2% rdg, ± 3 counts

DC Measurement

Measurement modes: mean value, ripple
 Input voltage range: 0 ... 1000 V
 Accuracy: ± 0.2% rdg, ± 3 counts

◆ **Digital Impulse Voltage Measuring System (SG3004)**

High voltage impulse test is used to assess the quality of any high voltage equipment. The test object is subjected to a fast voltage impulse of defined wave shape caused by the test object are used for detection of insulation strengths and/or faults.

SG3004-12(14) is an excellent and reliable tool for accurate measurement of all kinds of wave-shapes. It also

manufactures complete impulse voltage test systems to meet most requirement. This impulse generation capability plus impulse measurement offers a complete solution to modern testing needs.

Trigger: CH1, CH2 or Ext
 Resolution: 12bit
 Sampling rate: 100MS/sec max.
 Measuring time: 1-9999us
 Accuracy: ±1% T1, T2 and Tc (12bit)

Industry platform: TFT 23.5" TFT Screen
 Operating system: Window 10 or Window 8
 Number of Channels: Two (Independent) channels
 Input voltage: 1.5V-1500V
 Input impedance: 2MΩ/20pF
 Analog bandwidth: 50MHz for each channel

◆ **Ground Foil (GF)**

Copper ground foil, which can be used to make ground connections between the individual high voltage apparatus.

Weight: 0.45kg/m

Typical 100kV AC / 140kV DC Block Diagram:

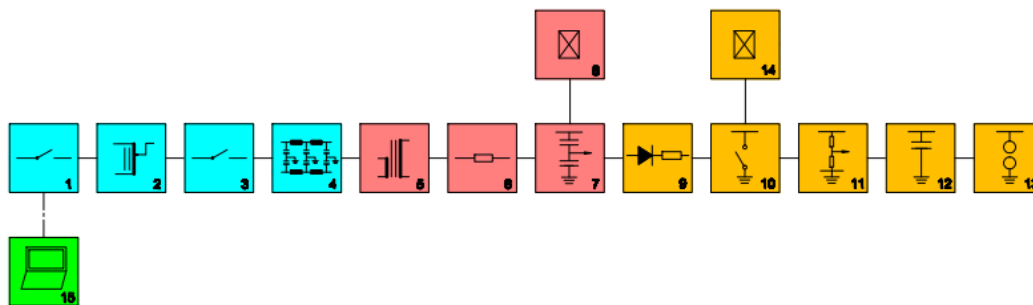

- | | | | |
|----------------------|-----------------------------------|-------------------------------|---------------------------------|
| Power Supply | HV Circuit (AC) | HV Circuit (DC) | Control and Measuring |
| 1 Switchgear Cabinet | 5 Test Transformer | 9 High Voltage Rectifier | 15 Control and Measuring System |
| 2 Voltage Regulator | 6 Damped Resistor | 10 Automatic Grounding Switch | |
| 3 Switchgear Cabinet | 7 Coupling Capacitor / HV Divider | 11 DC Resistive Divider | |
| 4 Power Noise Filter | 8 AC Test Object | 12 Filter Capacitor | |
| | | 13 HV Sphere Gap | |
| | | 14 DC Test Object | |



Typical 100kV AC / 250kV DC:

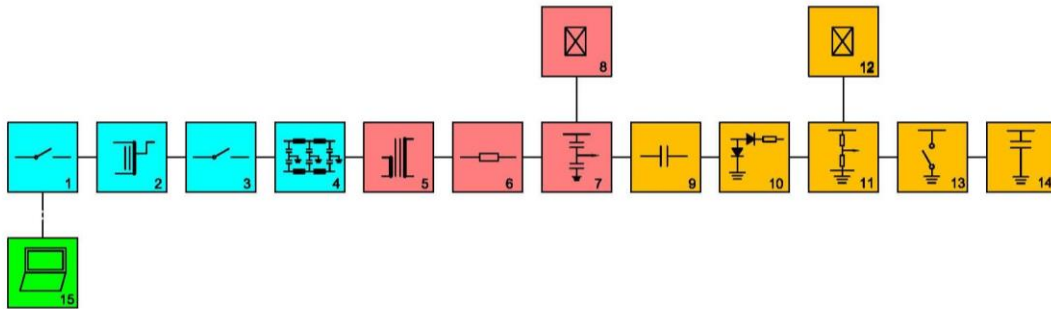

Power Supply

- 1 Switchgear Cabinet
- 2 Voltage Regulator
- 3 Switchgear Cabinet
- 4 Power Noise Filter

HV Circuit (AC)

- 5 Test Transformer
- 6 Damped Resistor
- 7 Coupling Capacitor / HV Divider
- 8 AC Test Object

HV Circuit (DC)

- 9 Double Voltage Capacitor
- 10 High Voltage Rectifier
- 11 DC Resistive Divider
- 12 DC Test Object
- 13 Automatic Grounding Switch
- 14 Filter Capacitor

Control and Measuring

- 15 Control and Measuring System

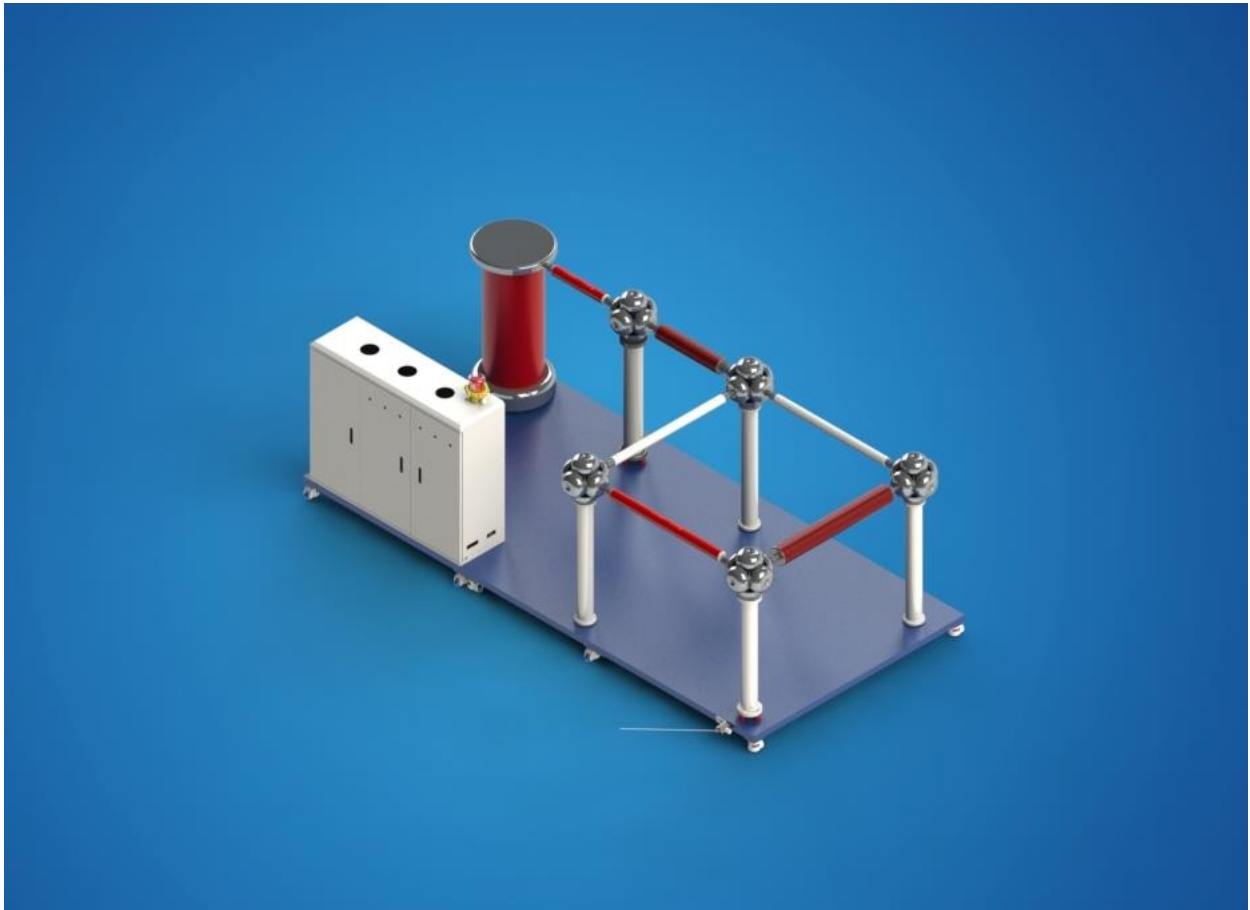

Typical 100kV AC / 140kV DC / 140kV LI-SI Block Diagram:

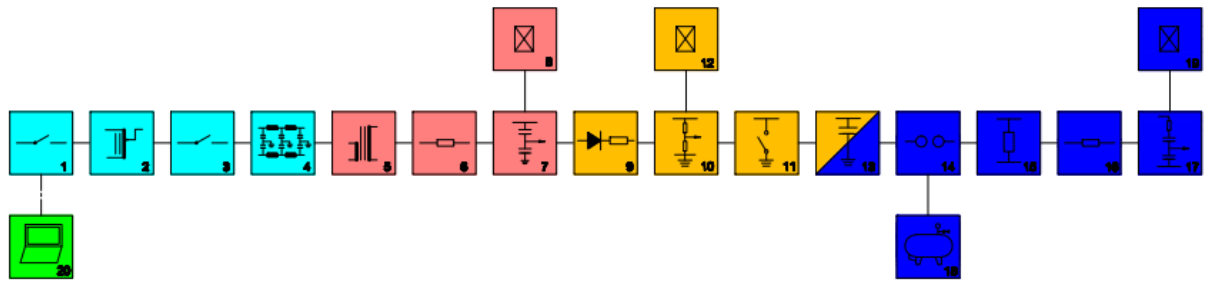

- | | | | | |
|----------------------|-----------------------------------|-------------------------------|-------------------------|---------------------------------|
| Power Supply | HV Circuit (AC) | HV Circuit (DC) | HV Circuit (IVG) | Control and Measuring |
| 1 Switchgear Cabinet | 8 Test Transformer | 9 High Voltage Rectifier | 14 Impulse Capacitor | 20 Control and Measuring System |
| 2 Voltage Regulator | 6 Damped Resistor | 10 DC Resistive Divider | 15 Discharge Sphere Gap | |
| 3 Switchgear Cabinet | 7 Coupling Capacitor / HV Divider | 11 Automatic Grounding Switch | 16 Tail Resistor | |
| 4 Power Noise Filter | 5 AC Test Object | 12 DC Test Object | 17 Front Resistor | |
| | | 13 Impulse Capacitor | 18 Weak Damping Divider | |
| | | | 19 Air Pump | |
| | | | 20 IVG Test Object | |

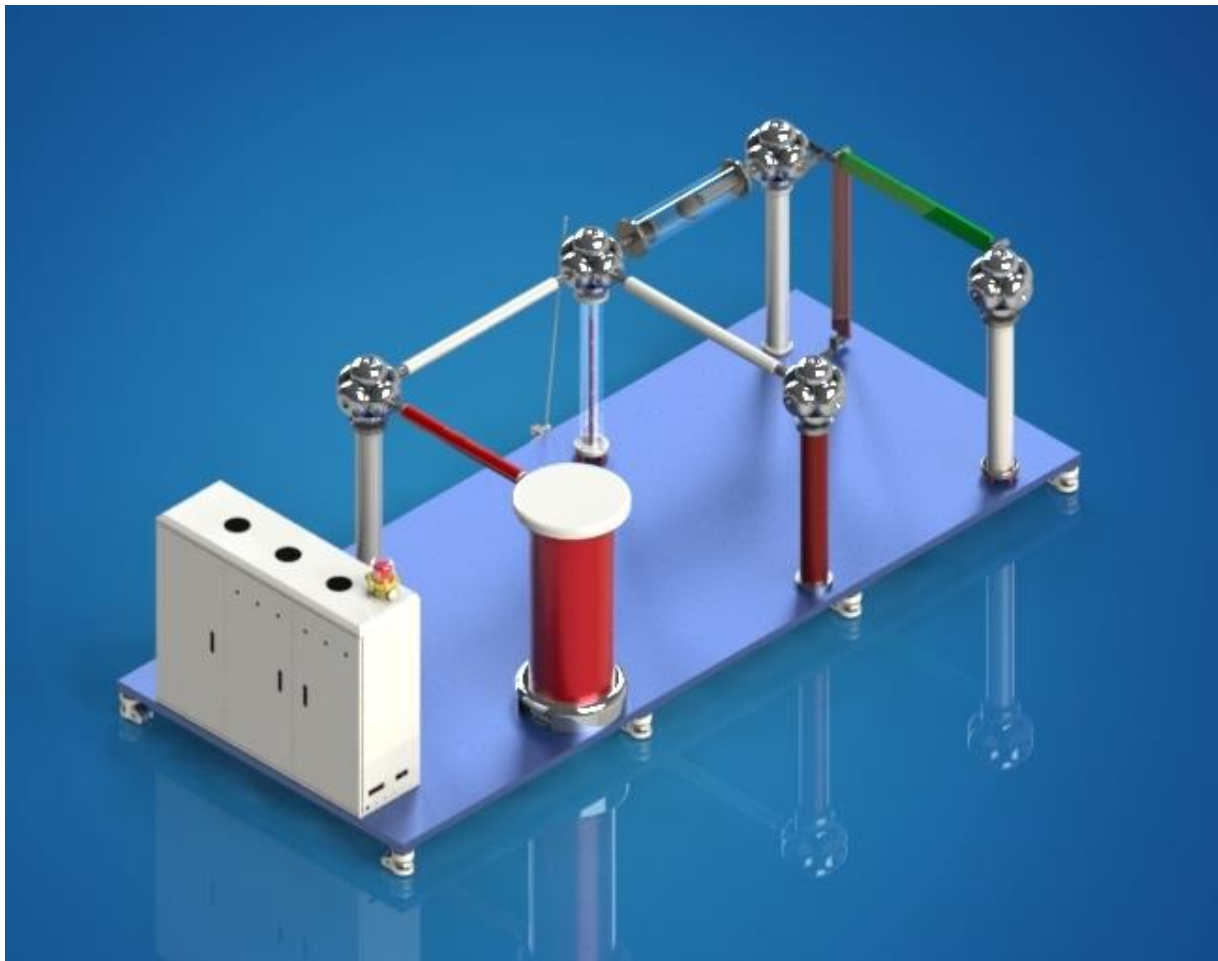

Typical 100kV AC / 250kV DC / 250kV LI-SI Block Diagram:

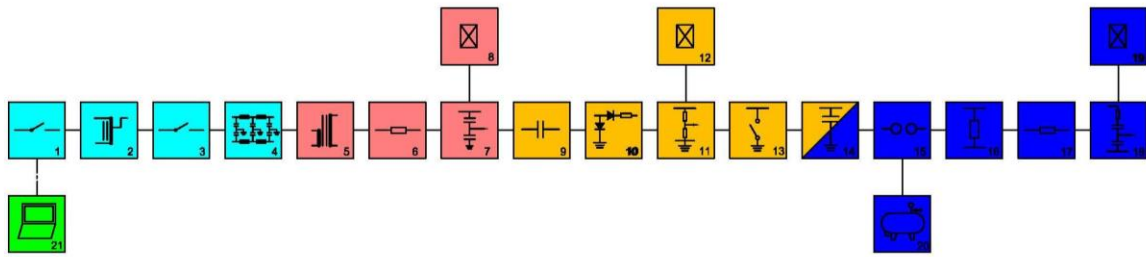

- | | | | | |
|----------------------|-----------------------------------|-------------------------------|-------------------------|---------------------------------|
| Power Supply | HV Circuit (AC) | HV Circuit (DC) | HV Circuit (IVG) | Control and Measuring |
| 1 Switchgear Cabinet | 5 Test Transformer | 9 Double Voltage Capacitor | 15 Impulse Capacitor | 21 Control and Measuring System |
| 2 Voltage Regulator | 6 Damped Resistor | 10 High Voltage Rectifier | 16 Discharge Sphere Gap | |
| 3 Switchgear Cabinet | 7 Coupling Capacitor / HV Divider | 11 DC Resistive Divider | 17 Tail Resistor | |
| 4 Power Noise Filter | 8 AC Test Object | 12 DC Test Object | 18 Front Resistor | |
| | | 13 Automatic Grounding Switch | 19 Weak Damping Divider | |
| | | 14 Impulse Capacitor | 20 Air Pump | |

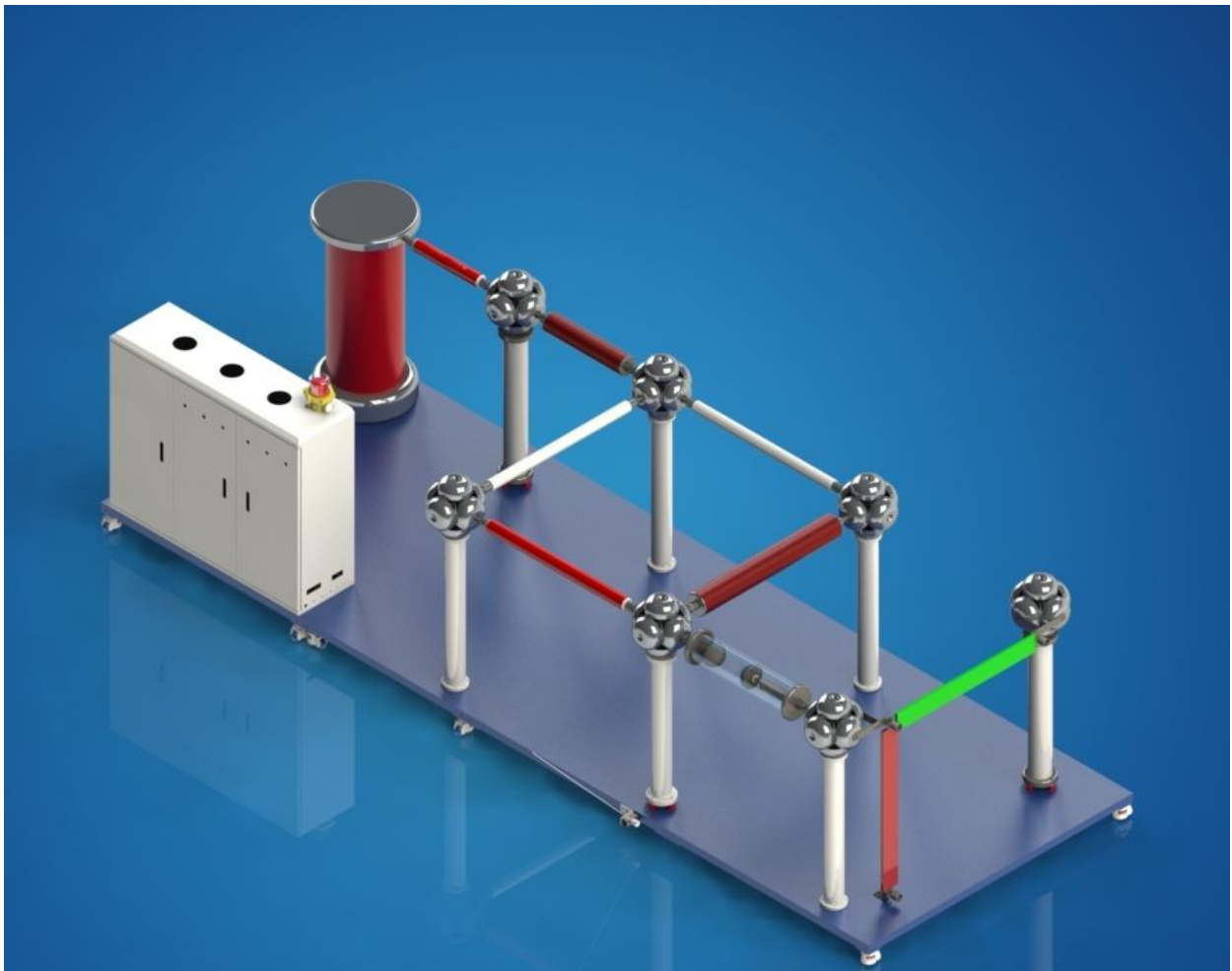

Typical 100kV AC / 250kV DC / 250kV LI-SI / 250kV LIC Block Diagram:

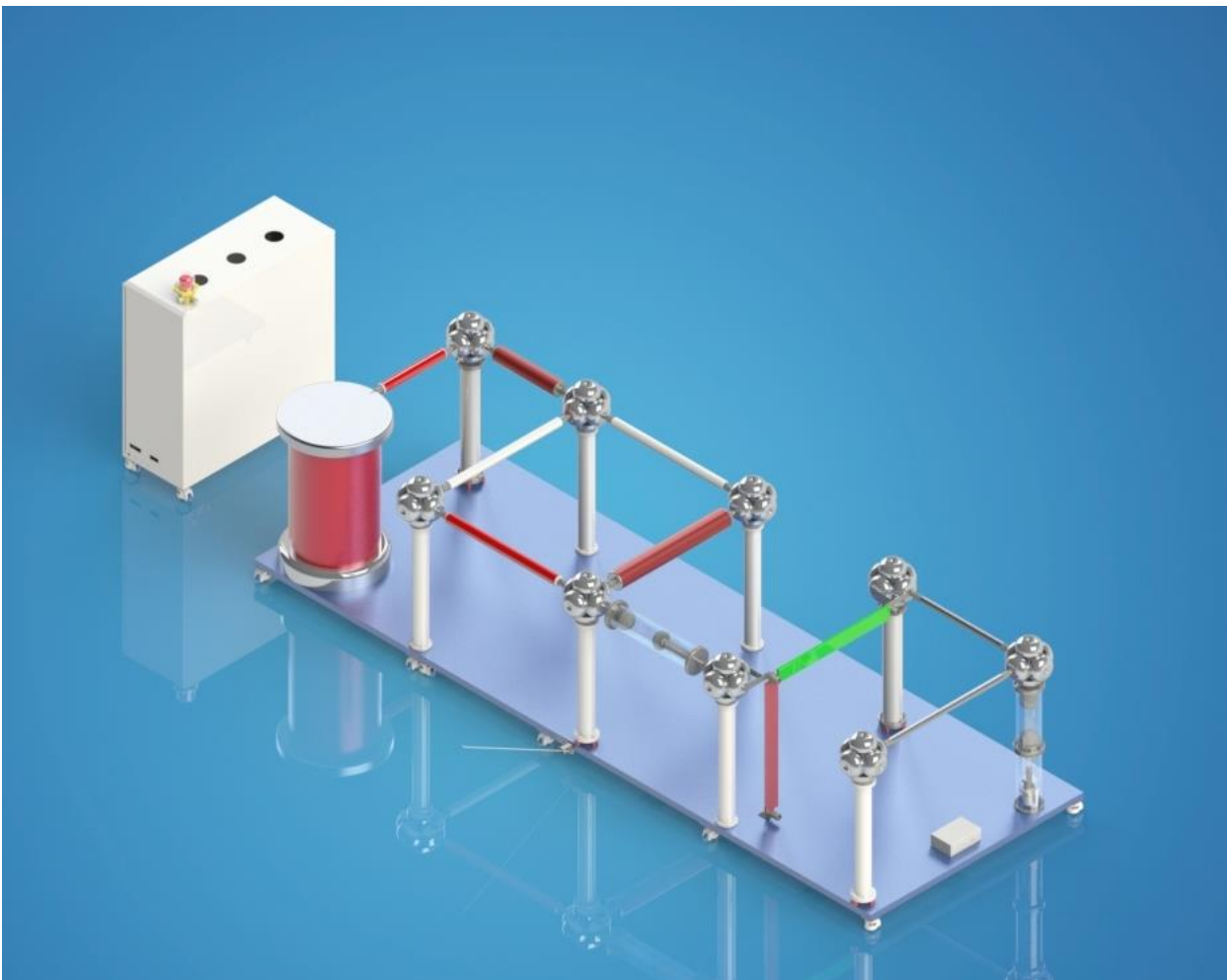
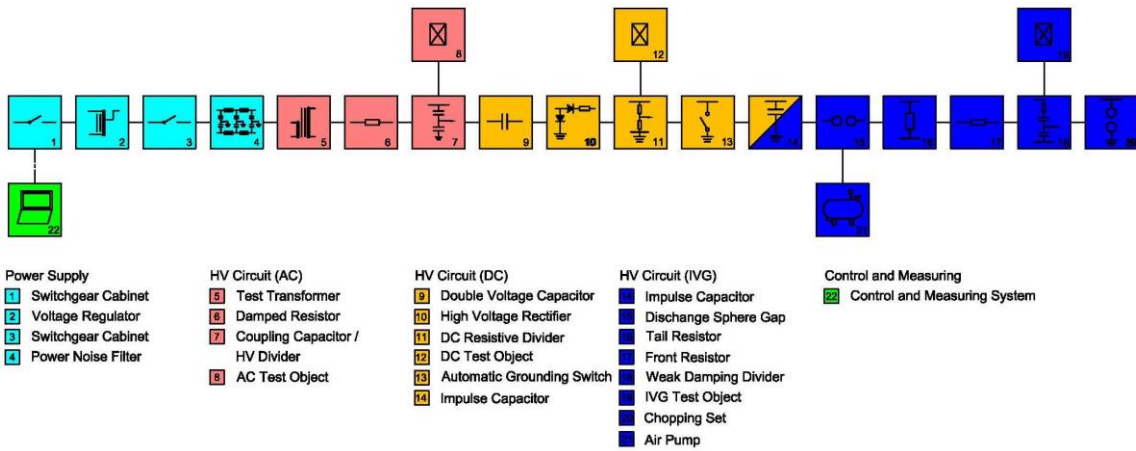

Test Room for SGADI series:

A suitable room is required to accommodate the SGADI series. Depending on the KIT configuration a floor surface of three by four meters is recommended, and a favorable height is 2.5 to 3 meters. Since voltages in excess of 1000 V are to be generated, it is necessary that the respective safety regulations are carefully followed. The most important criteria of a

good test room are the shielding and grounding.

Shielding

The test transformer of the high voltage construction KIT can be used for partial discharge measurements. The test transformer with the optional top electrode is partial discharge free. In order to ensure that the partial discharge measurement is not disturbed by external interference, it is necessary that the test room is a shielding room.

MSR series shielding room is newest technology for shielding room construction. Compare to widely used modular panel RF shielding construction technique, Samgor develop a evolution construction technique, our new develop MSR series shielding room use several module to construct a whole shielding room, the number of modules is from 1 to 20. Typical size of shielding room between 3m×2.4m×2.5m to 16m×12m×10.5m.

The basic construction and production technique of each module is similar to the normal container. So each module gets extremely high structural strength and extremely long working life.

Assemble and dismantle of MSR series shielding room is extremely easy compare to any similar size shielding room.

Traditional weld type shielding room and most of modular panel shielding room are very difficult to dismantled and relocated to another area, but MSR series shielding room can easy and quick done this work within few days.

Double shielding panels are be covered the whole shielding room, the first panels use the 1.5mm thick zinc coating steel plate are arranged in an overlapping manner, second shielding panel use 1.6mm thick, SPA-H steel panel with corrugation as also the outside decorative plate. It guarantee >75dB attenuation of electric field from 14kHz-1000kHz, >100dB attenuation of magnetic field from 200kHz-1000kHz.

For preservation, the MSR series shielding room is use three layers surface treatment, first layer is epoxy zinc rich primer for 20 microns, second layer is intermediate coating for 40 microns, third layer is polyurethane top coating for 50 microns. Good surface treatment guarantee long working life up to 100 years and very nice outlook compare to normal shielding room

Grounding

A good test field has a separate grounding. This ensures that no disturbances from surrounding machines enter the test field and - in case of a failure - the earth potential of the surrounding does not rise, causing damage to electrical equipment. It is necessary for the test field to have a lower grounding resistance than the surrounding building.



The following measures are required: Use a deep ground rod, radial ground wires below the ground surface, a lightning conductor or water mains outside the building for grounding. If possible, the whole test room should be screened. Attention should be paid to ensure a good lasting electrical connection between all parts of the screening.

The screening surfaces should be made with wide metal strips (at least 60 mm in width), since strips of this width are of lower inductivity than round wires having the same cross-sectional area. Connections have to be made without forming loops. The ground connection of the high voltage generator, measuring system and test object should be arranged like a star, where the central point is grounded.

To avoid ground loops between different grounding points, the KIT is grounded at only one position through a grounding rod. The rod must have a ground resistance of less than 2 Ω . If the resistivity of the soil near the factory is not known, we recommend the following procedure: A rod with a diameter of about 20 mm is driven into the soil to a depth of approx. 30 m. The first 3 m of this rod below the soil level have to be insulated in order to avoid picking up surface currents. Then the ground resistance is measured. If the resistance is higher than 2 Ω , a second rod must be driven into the soil approx. 10 m from the first, following the same procedure.

The two ground rods are then connected in parallel with a copper foil of 150 x 0.3 mm cross section for example. This procedure is repeated until the ground resistance of < 2 Ω is achieved. 27 The length of the grounding rod is not important but the ground resistance must be < 2 Ω for personnel protection. A local construction company can give you some more details about the depth of the rod. The grounding rod(s) shall be placed close to the test area. The enclosure's ground stud will be connected to the ground rod with a strong copper band for example 0.3 x 100 mm.

For further information please contact:

Samgor Technology

Add: No.2979A Chuansha Rd.

Pudong, Shanghai, China (201201)

Tel: 86-21-58999556

Fax: 86-21-58999556

E-mail: info@samgor.com

Http:// www.samgor.com

